

# BUTLERBUILT®

“SETTING THE STANDARD”



**Tig says “Enhance the safety in your Sprint Car/Midget with Proper Seat Mounting”**

## MOUNTING THE SPRINT ADVANTAGE HEAD

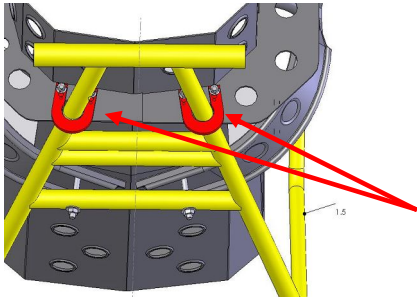

For maximum performance of the ButlerBuilt Sprint Advantage seat, the “Horseshoe” Brackets provided **MUST** be installed around the vertical A-Post tubes to the head surround flange. Notching of the flange may be necessary to allow for proper positioning for the driver.

Two (2) ¼-20 x ¾ Grade 8 Flange Bolts and Two (2) ¼-20 Locking Flange Nuts are required to mount each bracket to the flange.

## MOUNTING THE SEAT BACK

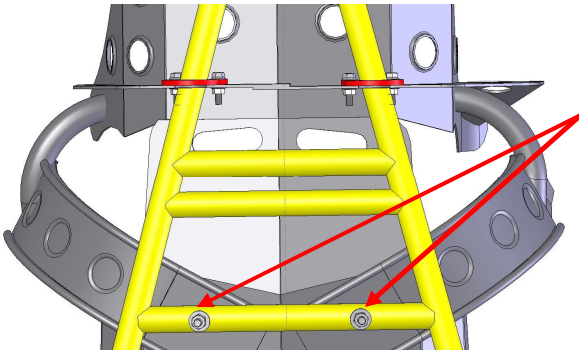

The seat back **MUST** be securely bolted to an A-frame cross bar with a **minimum** of two (2) 5/16 **minimum** Grade 8 bolts and locknuts with large hardened flat washers. The distance between the bolts should be as wide as possible to spread the load.

## MOUNTING THE SEAT BOTTOM

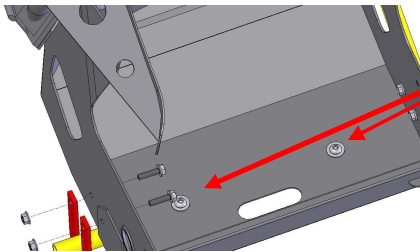

The seat bottom **MUST** be securely bolted to the chassis with **minimum** of two (2) 5/16 **minimum** Grade 8 bolts and locknuts with large hardened flat washers

## MOUNTING THE SEAT SIDES

The “King Klamp” should be used to help distribute the forces acting on the seat in the event of an impact. Simply slide the bracket over the seat mount chassis tube and position in such a way where the two 5/16-18 x 1 Grade 8 Flange bolts will be fastened through the side of the seat and secured with two (2) 5/16-18 locking flange nuts. When possible, the bolts should be inserted through the reinforced area of the seat

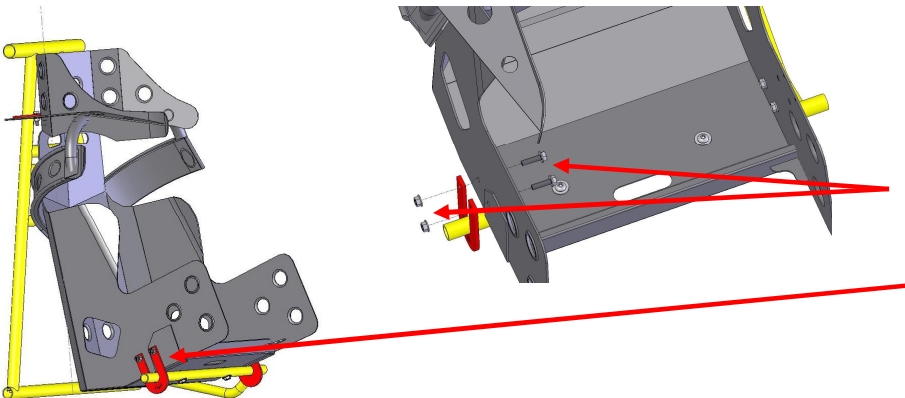

# BUTLERBUILT®

“SETTING THE STANDARD”



**Tig says “Enhance the safety in your Sprint Car/Midget with Proper Seat Belt Mounting”**

## Lap Belts

Lap belts should be positioned in such a manner to pull equally down as well as back, forcing the driver into the seat bottom and back area. A good way to judge this position is to look at the seat from the side. The lap belt should be directed toward the bottom corner of the seat.

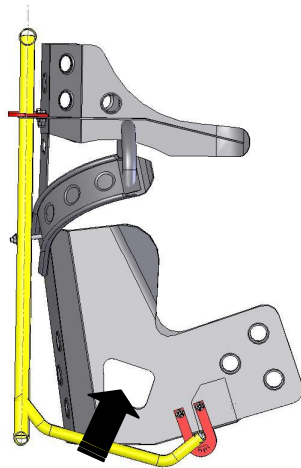

Tube Angle 25°-30°  
Seat Belt Angle 60° - 65°

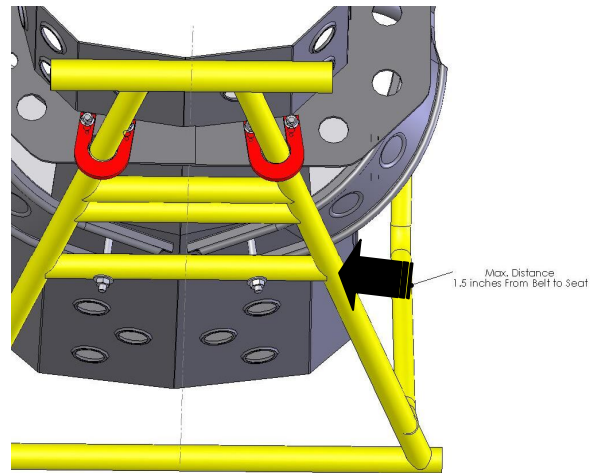

Seat Belt should be mounted **less than 1.5 in.** away from the side of the seat.

## Shoulder Harness

Shoulder harnesses should be positioned in such a manner to pull perpendicular to the drivers spine. This allows the drivers upper body no forward movement.

In addition to the angle of the shoulder harness, the placement of the crossbar in the chassis is critical to proper seat belt mounting. **The A frame crossbar MUST be no lower than 1 in. below the shoulder harness holes in the seat.** This allows the chassis to support the load of the drivers weight.

Finally, the shoulder harness should be mounted as short as possible to reduce belt stretching.

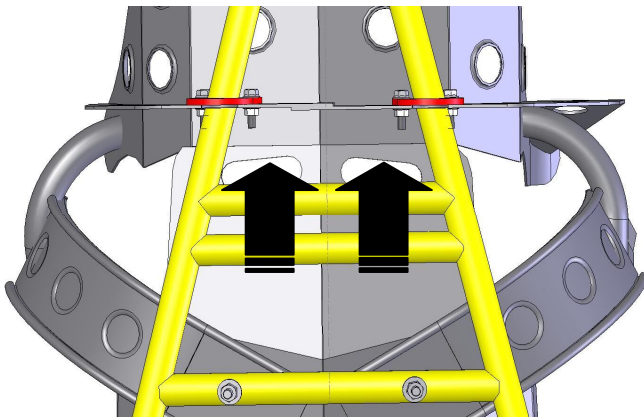

BUTLERBUILT®  
**Motorsports Equipment**  
Mail to: PO Box 1270  
Harrisburg NC 28075  
Ship to: 70 Pitts School Rd NW  
Concord, NC 28027  
Tel: 704-784-1027  
Fax: 704-784-1024  
[www.butlerbuilt.net](http://www.butlerbuilt.net)  
[sales@butlerbuilt.net](mailto:sales@butlerbuilt.net)